

FUEL DEPOT HAZARDS MAP



DISTANCES SHOWN ARE BASED ON THE CLASSIFICATION OF HAZARDOUS AREAS AS CONTAINED IN AUSTRALIAN STANDARD AS/NZS 60079.10.1:2009. THIS MAP DOES NOT CONTAIN EVERY PROVISION OF THE STANDARDS THAT MAY APPLY AT A FUEL DEPOT. FOR ADDITIONAL INFORMATION CONTRACTORS SHOULD REFER TO THE RELEVANT PART OF AS/NZS 60079.10.1:2009

FOR PURPOSES OF CLARITY, THE VERTICAL EXTENT OF THE HAZARDOUS AREAS IS NOT SHOWN ON THIS MAP. FOR WORK CLEARANCE PURPOSES, WORK AT ANY HEIGHT WITHIN THE SITE BOUNDARY THAT HAS THE POTENTIAL TO CAUSE AN IGNITION SOURCE TO ENTER THIS AREA WILL REQUIRE THE CONTRACTOR TO CONTACT THE COMPANY REPRESENTATIVE.

THE EXTENT OF THE HAZARDOUS AREAS MAY INCREASE UNDER YOUR ASSESSMENT BUT MUST NOT BE LESS THAN THE DISTANCES SHOWN.

THE EXTENT OF THE HAZARDOUS AREA IS SHOWN THUS: 

THE EXTENT OF THE AREA WITHIN THE SITE BOUNDARY IS SHOWN THUS: 

THE OFFICE AND THE DESIGNATED HOT WORK AREA (WHERE DEFINED) ARE EXCLUDED AREAS:

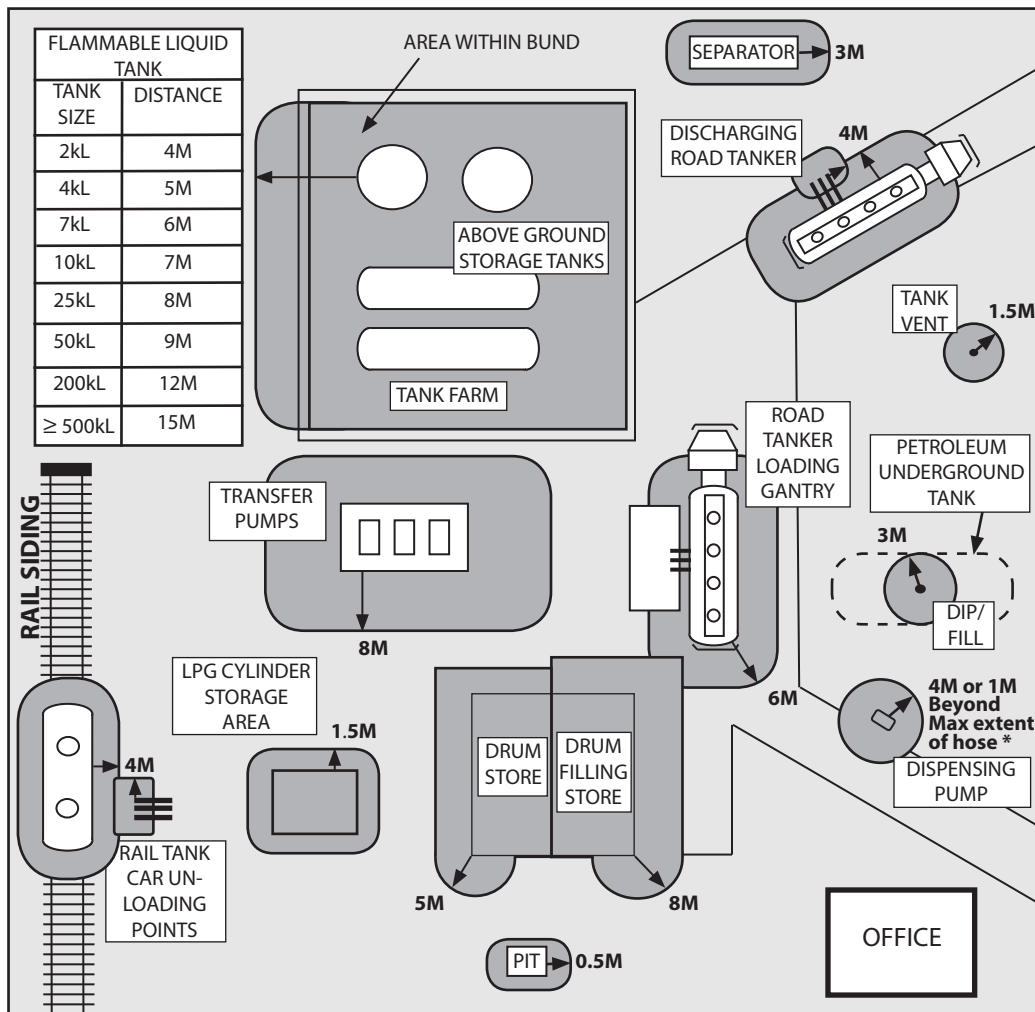

* WHICHEVER IS THE GREATER

SMOKING IS NOT PERMITTED ON SITE